



at&t

User's manual

TL7100

Handset lifter

for use with AT&T models

TL7610/TL7612/

TL7810/TL7812



Congratulations

on your purchase of this AT&T product. Before using this AT&T product, please read the **Important safety information** section on page 25 of this manual. Please thoroughly read this user's manual for all the feature operations and troubleshooting information necessary to install and operate your new AT&T product. You can also visit our website at **www.telephones.att.com** or call **1 (800) 222-3111**. In Canada, dial **1 (866) 288-4268**.

Model number: TL7100

Type: Handset lifter

Serial number: _____
(found on the bottom of the handset lifter)

Purchase date: _____

Place of purchase: _____

Save your sales receipt and original packaging in case it is necessary to return this product for warranty service.

Parts checklist

Check to make sure the handset lifter package includes the following items. Save your sales receipt and original packaging in the event warranty service is necessary.



User's manual



Handset lifter



Anti-slip pad



Large lifter pad

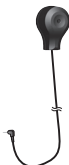

Auxiliary ring detector



TL7610/TL7612 base adapter

User's manual

TL7100

Handset lifter

for use with AT&T models

TL7610/TL7612/TL7810/TL7812



Table of contents

Getting started

Quick reference guide - handset lifter	1
Installation options.....	3
To install the lifter on your TL7610/TL7612 headset base	3
To install the lifter on your TL7810/TL7812 headset base	3
Headset base installation - TL7610/TL7612.....	4
TL7610/TL7612 headset base installation.....	4
Adjust the corded handset audio.....	6
Headset base installation - TL7810/TL7812.....	7
TL7810/TL7812 headset base installation.....	7
Adjust the corded handset audio.....	11
Handset lifter installation.....	12
Attach the lifter.....	12
Adjust the switch hook presser position.....	13
Adjust the height of the lifter arm.....	13
Lifter adjustments and testing.....	14
Installation of large lifter pad (optional).....	15
Installation of anti-slip pad (optional).....	15
About internal and auxiliary ring detectors.....	16
Install the auxiliary ring detector.....	16
Ring detector on/off.....	17
Adjust the sensitivity level.....	17
STATUS light.....	18

Make and answer calls.....	19
Make and answer a call with the handset lifter and cordless headset.....	19
Make and answer a call with a multi-line telephone and the handset lifter.....	20

Appendix

Troubleshooting	21
Maintenance.....	24
Important safety information	25
Safety information.....	25
FCC Part 15.....	26
Limited warranty.....	27

Index

Index	31
-------------	----

Quick reference guide - handset lifter

SENSOR ADJ knob

Adjusts the sensitivity of the ring detector (page 17).

ADJUST LIFTER knob

Adjusts the height of the lifter arm (page 13).

Lifter arm

Holds the corded telephone handset.

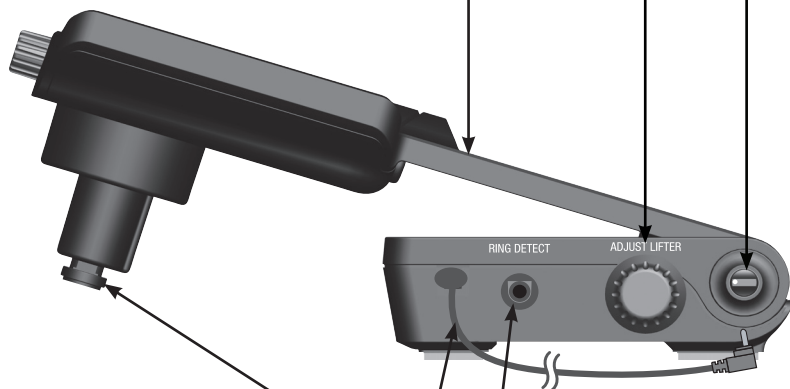

Switch hook presser

Press **ON/OFF** (TL7610/TL7612) or **⏻** (TL7810/TL7812) on the headset rises or lowers the switch hook presser.

Lifter control cable

This cable is hard wired into the lifter and plugs into the **LIFTER** jack on the TL7610/TL7612 headset base via the TL7610/TL7612 base adapter, or the **LIFTER** jack on the TL7810/TL7812 headset base.

RING DETECT jack

Plug in the auxiliary ring detector (page 16).

Quick reference guide - handset lifter

RING ON/OFF

Press to turn the ring detector on or off. When the ring detector is off, the cordless headset does not ring (page 17).

Switch hook presser adjustment knob

Adjusts the position of the switch hook presser (page 13).

Small lifter pad

Holds the earpiece of the corded telephone handset.

STATUS light

On in red when the ring detector is off (page 18).

On in blue when the ring detector is on and the headset is not in use (page 18).

Flashes in blue four times every three seconds when the ring detector detects an incoming call (page 18).

Flashes in blue slowly when the switch hook presser is raised and you are on a call (page 18).

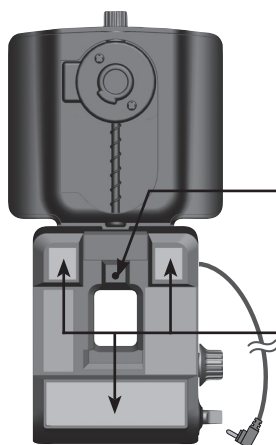
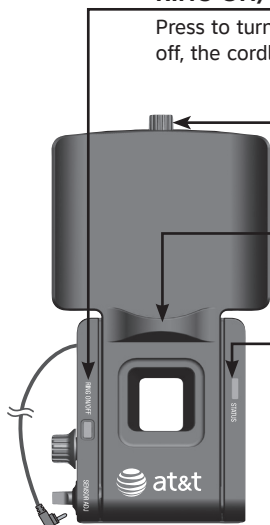

Internal ring detector

Detects the telephone ringer and sends a ring tone to the headset earpiece.

Adhesive tape

Remove the protective strips before attaching the lifter to the telephone base.

Installation options

The TL7100 lifter works with the TL7610/TL7612/TL7810/TL7812 DECT 6.0 cordless headset to provide a complete communication solution for most corded telephones. The lifter raises and lowers its switch hook presser to answer, make and end phone calls. The ring detector provides an incoming call indication through the cordless headset, so you can answer calls even if you are away from the telephone base.

The cords have colored labels that guide you to plug them into the correct headset base jacks. The back of the headset base has color-coded dots and the names of the jacks above them that correspond to the colored labels on the cords.

To install the lifter on your TL7610/TL7612 headset base

See pages 4-5 to connect the TL7100 lifter to a TL7610/TL7612 headset base using the TL7610/TL7612 base adapter provided in the package. You can use the headset to remotely control the lifter for answering or hanging up a call.

To install the lifter on your TL7810/TL7812 headset base

There are two installation options to connect the TL7100 lifter to a TL7810/TL7812 headset base.

- Option 1:** Connect the headset to a corded phone (see pages 7-8). This option allows you to use the headset to remotely control the lifter for answering or hanging up a call.
- Option 2:** Connect the headset to a corded phone and computer (see pages 9-10). This option enables you to use the headset for VoIP (Voice over IP) calls through your computer, or traditional phone call through the corded phone.

For customer service or product information, visit our website at **www.telephones.att.com** or call **1 (800) 222-3111**. In Canada, dial **1 (866) 288-4268**.

Headset base installation - TL7610/TL7612

TL7610/TL7612 headset base installation

1. Before installing the headset base, remove the rear bottom piece of the headset base by pushing it away from the base.

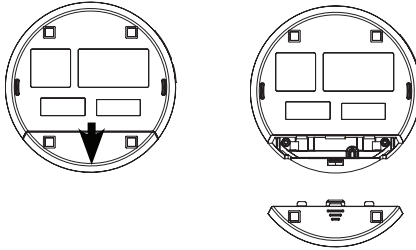

2. Unplug the curly handset cord from the telephone and plug it into the **CURLY CORD** jack (light blue dot) on the headset base.

Plug the small end of the headset base power adapter to the **POWER** jack (green dot) on the headset base.

Plug the large end of the headset base power adapter into a power outlet not controlled by a wall switch.

Telephone wall jack

A DSL filter (not included) is required if you have DSL high-speed Internet service.

Telephone line cord

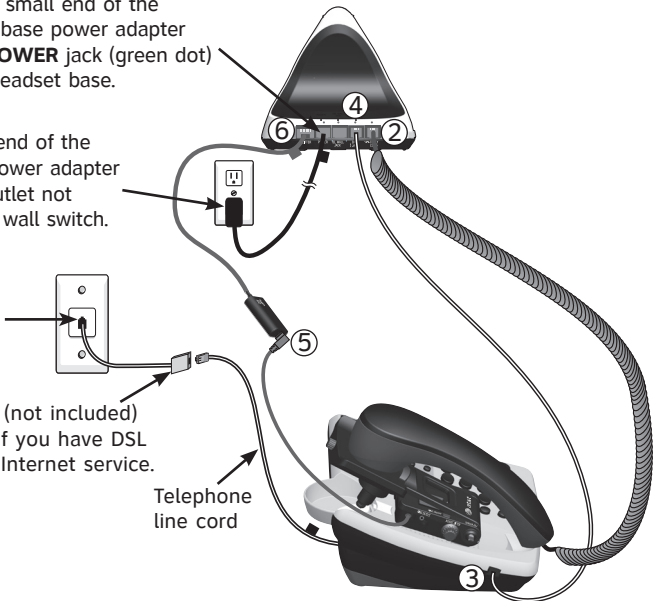

Headset base installation - TL7610/TL7612

TL7610/TL7612 headset base installation (cont.)

3. Plug one end of the telephone line cord (provided with the headset base) into the base handset jack on the telephone where the curly handset cord was plugged in.
4. Plug the other end of the line cord into the **BASE) JACK** (orange dot) on the headset base.
5. Plug the lifter control cable into the jack of the TL7610/TL7612 base adapter.
6. Plug the other end of the TL7610/TL7612 base adapter into the **LIFTER** jack (blue dot) on the headset base.
7. After completing installation, slide the rear bottom piece towards the headset base until it clicks into place.

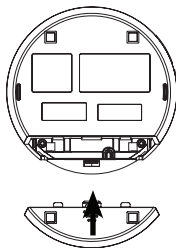

8. Adjust the corded handset audio (see page 6) before you install the handset lifter on your corded phone.
9. For instructions of installing the lifter, see pages 12-14. For information about the internal and auxiliary ring detectors, refer to pages 16-18.

Headset base installation - TL7610/TL7612

Adjust the corded handset audio

1. Make sure that **LIFTER MODE** light on the headset base is on. Press the **MODE** button on the headset base to change the mode.
2. Lift the corded handset to release the switch hook. Place the corded handset aside.
3. Place the headset earpiece (AT&T model TL7610/TL7612) in your ear.
4. Press **ON/OFF** on the headset to listen for a dial tone. If there is no dial tone or the dial tone is unclear, slide the **LIFTER AUDIO ADJUST** switch on the side of the headset base from **A** to **G** until the dial tone is clear.

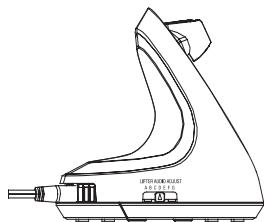
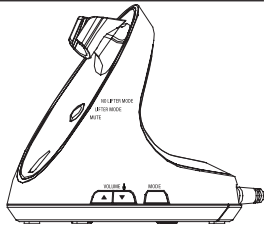

Headset base installation - TL7810/TL7812

TL7810/TL7812 headset base installation

Option 1: Connect the headset to a corded phone

1. Plug one end of the corded phone connection cable into the **CORDED PHONE CONNECTION** jack (blue dot) at the back of the headset base.
2. Plug the other end of the corded phone connection cable into the handset jack on the corded phone.
3. Unplug the curly handset cord from the handset jack on the corded phone and plug it into the jack on the corded phone connection cable.
4. Plug the small end of the headset base power adapter to the **POWER** jack (green dot) on the headset base.

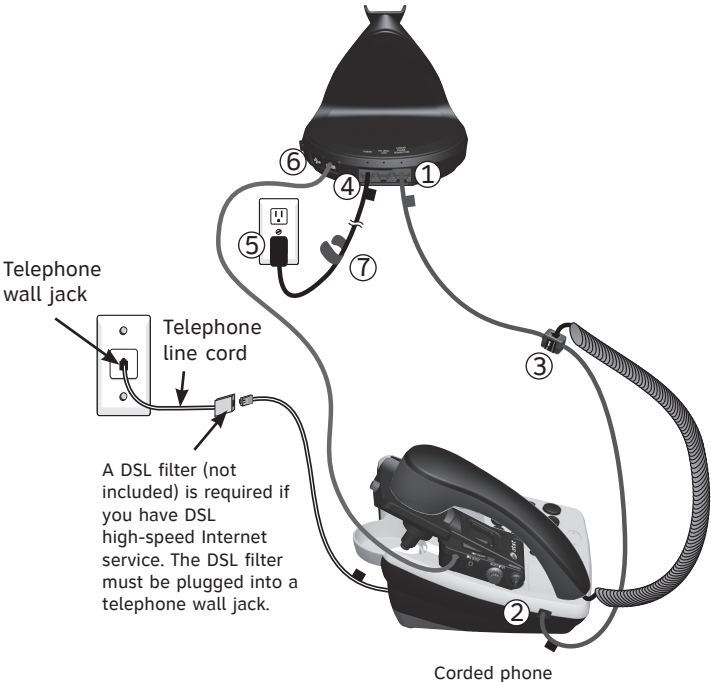

Headset base installation - TL7810/TL7812

TL7810/TL7812 headset base installation (cont.)

5. Plug the large end of the headset base power adapter into a power outlet not controlled by a wall switch.
6. Plug the end of the lifter control cable into the **LIFTER** jack at the back of the headset base.
7. Use the attached fastener to bundle all line cords neatly.
8. Make sure the **CORDED HANDSET CONNECTED** switch on the right side of the headset base is set to **YES**.
9. Adjust the corded handset audio (see page 11) before you install the handset lifter on the corded phone.
10. For instructions of installing the lifter, see pages 12-14. For information about the internal and auxiliary ring detectors, refer to pages 16-18.



Headset base installation - TL7810/TL7812

TL7810/TL7812 headset base installation (cont.)

Option 2: Connect the headset to a corded phone and computer

1. Plug one end of the corded phone connection cable into the **CORDED PHONE CONNECTION** jack (blue dot) at the back of the headset base.
2. Plug the other end of the corded phone connection cable into the handset jack on the corded phone.
3. Unplug the curly handset cord from the handset jack on the corded phone and plug it into the jack on the corded phone connection cable.

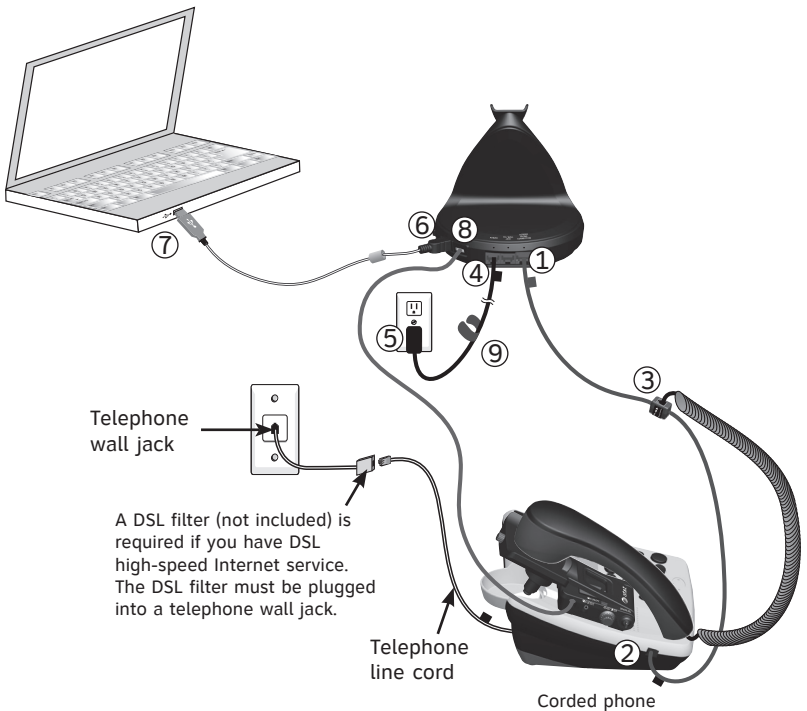

Headset base installation - TL7810/TL7812

TL7810/TL7812 headset base installation (cont.)

4. Plug the small end of the headset base power adapter to the **POWER** jack (green dot) on the headset base.
5. Plug the large end of the headset base power adapter into a power outlet not controlled by a wall switch.
6. Plug the small end of the USB cable into the USB port labeled  on the right side of the headset base.
7. Plug the large end of the USB cable into a USB port on your computer. Wait for your computer to indicate that it has recognized the headset.
8. Plug the end of the lifter control cable into the **LIFTER** jack at the back of the headset base.
9. Use the attached fastener to bundle all line cords neatly.
10. Make sure the **CORDED HANDSET CONNECTED** switch on the right side of the headset base is set to **YES**.
11. Adjust the corded handset audio (see page 11) before you install the handset lifter on the corded phone.
12. For instructions of installing the lifter, see pages 12-14. For information about the internal and auxiliary ring detectors, refer to pages 16-18.
13. Download and install the **AT&T Softphone Call Manager** on your computer. The software is available for download at **www.smbtelephones.att.com/downloads**.
For detailed installation and operating information, refer to the **Installation and Operation Guide for AT&T Softphone Call Manager**, available for download at **www.smbtelephones.att.com/downloads**.
14. Refer to the **Audio settings** section in the **Installation and Operation Guide** to configure the audio settings.



Headset base installation - TL7810/TL7812

Adjust the corded handset audio

After you have connected the headset base to your corded phone, you may need to adjust the corded handset audio switch at the bottom of the headset base for optimal sound quality.

To adjust the corded handset audio:

- Lift the corded handset and then press **⏻** on the headset to check for a dial tone. If there is no dial tone or the dial tone is unclear, slide the corded handset audio switch at the bottom of the headset base from **A** to **F** until the dial tone is clear.

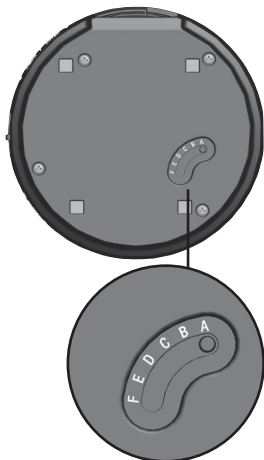

Handset lifter installation

Adjust the switch hook presser position

Turn the knob to move the switch hook presser until it is lined up with your telephone switch hook.

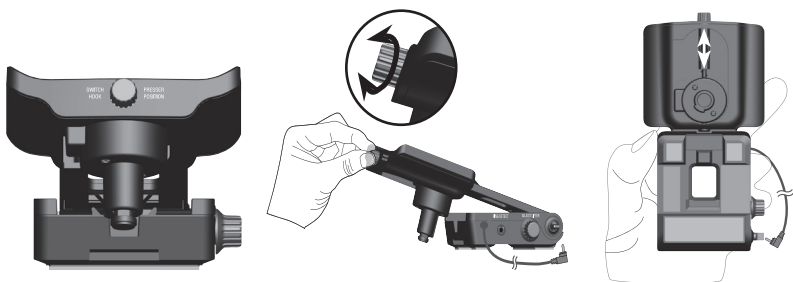



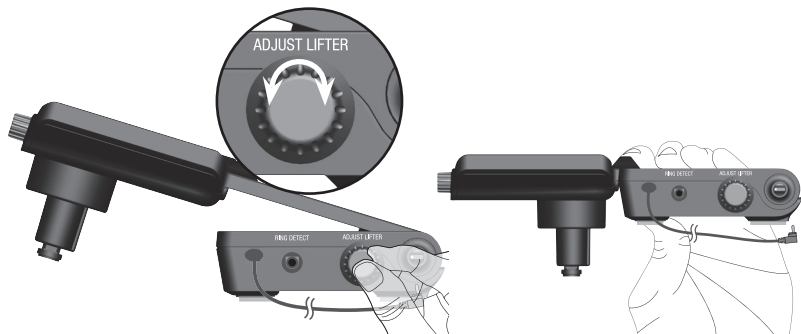

Adjust the height of the lifter arm

Turn the **ADJUST LIFTER** knob to change the height of the lifter arm. When in the raised position, the arm should release the switch hook so you can hear a dial tone. When lowered, the arm should hold the switch hook down so you cannot hear a dial tone.

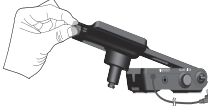

Handset lifter installation

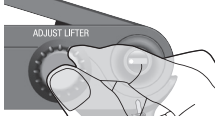
Lifter adjustments and testing

1. Make sure that **LIFTER MODE** light on the TL7610/TL7612 headset base is on, or the **CORDED HANDSET CONNECTED** switch is turned to **YES** on the TL7810/TL7812 headset base. Make sure the **LIFTER AUDIO ADJUST** setting is correct.
2. Turn the switch hook presser adjustment knob until the switch hook presser is just above the switch hook (see page 13).
3. Lower the lifter arm until the switch hook presser holds the switch hook down.
4. Place the corded handset on the lifter.
5. Press **ON/OFF** (TL7610/TL7612) or **⏻** (TL7810/TL7812) on the headset. The switch hook presser should rise and release the switch hook on your telephone base. Make sure you hear a dial tone through your headset earpiece.
6. If the switch hook is not fully released, turn the **ADJUST LIFTER** knob (see page 13) while the corded handset is on the lifter. When the switch hook is fully released, you will hear a dial tone from the headset.

It may take some adjustments and testing to find the right position for the lifter. For the lifter to work properly, the switch hook must release completely when you press **ON/OFF** (TL7610/TL7612) or **⏻** (TL7810/TL7812) to turn the headset on. The switch hook must also be held down completely when you press **ON/OFF** (TL7610/TL7612) or **⏻** (TL7810/TL7812) to turn the headset off.

Handset lifter installation

Installation of large lifter pad (optional)

If the small lifter pad cannot hold the corded handset steadily, you can attach a large lifter pad (provided) to enlarge the contact area.

1. Hold the large lifter pad in front of the small lifter pad as shown below.
2. Insert the large lifter pad into the two front gaps of the small lifter pad.

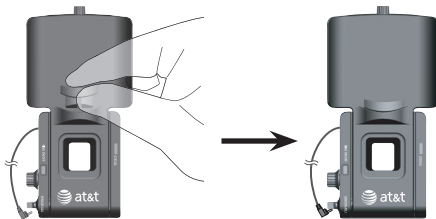

Installation of anti-slip pad (optional)

The anti-slip pad (provided) helps prevent your corded handset from slipping from the lifter.

1. Position the anti-slip pad above the small lifter pad.
2. Peel off the protective strip from the anti-slip pad.
3. Carefully return the anti-slip pad to the predetermined position and replace the corded handset on the lifter.

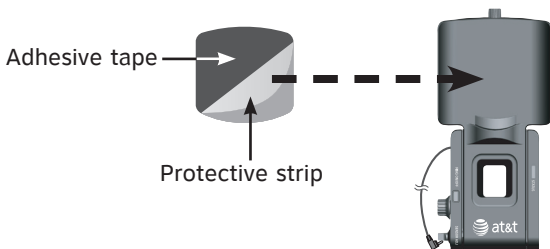

About internal and auxiliary ring detectors

The internal or auxiliary ring detector detects the telephone ringer and sends a ring tone to the headset earpiece.

If you installed the TL7100 lifter over the top of the corded phone speaker, the internal ring detector will recognize when the phone rings. However, if your corded phone speaker is located elsewhere on the phone, stick the auxiliary ring detector to the speaker as shown below.

Install the auxiliary ring detector

1. Insert the auxiliary ring detector plug into the **RING DETECT** jack on the lifter.
2. Remove the protective strip from the adhesive tape on the auxiliary ring detector.
3. Stick the auxiliary ring detector to the center of the corded phone speaker.

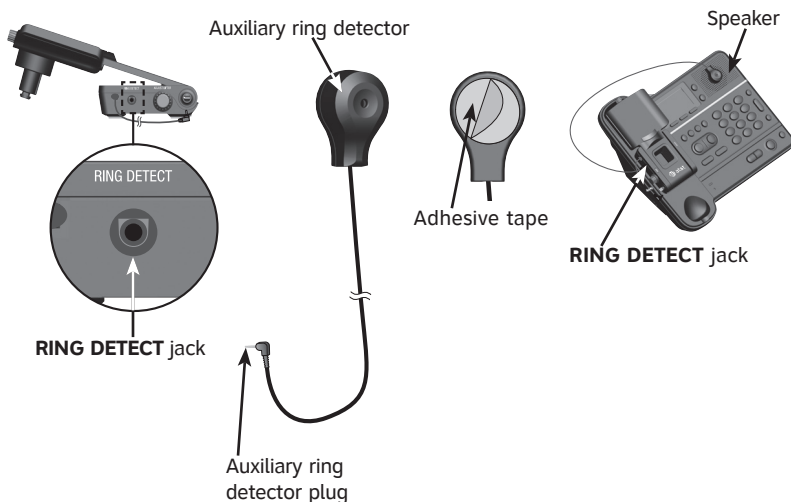

About internal and auxiliary ring detectors

Ring detector on/off

When the ring detector detects an incoming call, it sends a ring tone to the headset earpiece.

- Press the **RING ON/OFF** button on the lifter to turn the ring detector on or off. The **STATUS** light is blue when the ring detector is turned on. The **STATUS** light is red when the ring detector is turned off.
- When the ring detector is turned off, it does not send a ring tone to the headset.



NOTE: When you are using your telephone's speakerphone, the ring detector may send a ring tone to the headset. If you do not want the headset to ring, press the **RING ON/OFF** button to turn the ring detector off. After the call, you can press the **RING ON/OFF** button again to turn the ring detector back on.

Adjust the sensitivity level

The default setting of the ring detector works with most corded telephones. However, the ring detector might need some adjustments to recognize less common telephone ring tones.

To adjust the ring detector sensitivity while the telephone is ringing:

- Turn the **SENSOR ADJ** knob clockwise to increase the sensitivity.
- Turn the **SENSOR ADJ** knob counterclockwise to decrease the sensitivity.



When the ring detector detects the telephone ringer correctly:

- The **STATUS** light on the lifter flashes quickly when the telephone rings.
- The detector sends the ring tone to the headset earpiece.

About internal and auxiliary ring detectors

STATUS light

Red	<ul style="list-style-type: none">• On when the headset is not in use and the ring detector is turned off.• Flashes slowly when the headset is in use and the ring detector is turned off.
Blue	<ul style="list-style-type: none">• On when the headset is not in use and the ring detector is turned on.• Flashes four times every three seconds when the ring detector detects an incoming call.• Flashes slowly when the headset is in use and the ring detector is turned on.
Off	<ul style="list-style-type: none">• The headset base does not have power.• The lifter control cable is not plugged into the LIFTER jack on the TL7610/TL7612 headset base via the TL7610/TL7612 base adapter, or the LIFTER jack on the TL7810/TL7812 headset base.

Make and answer calls

Make and answer a call with the handset lifter and cordless headset

You can use the cordless headset to make, answer and end calls without using the corded handset.

Make a call:

1. Press **ON/OFF** (TL7610/TL7612) or **☎** (TL7810/TL7812) on the headset. The switch hook presser rises and releases the switch hook. You hear a dial tone in the headset earpiece.
2. Dial the telephone number using the dialing keys.



Answer a call:

- Press **ON/OFF** (TL7610/TL7612) or **☎** (TL7810/TL7812) on the headset to answer an incoming call. The switch hook presser rises and releases the switch hook. You hear the caller through the headset earpiece.

End a call:

- Press **ON/OFF** (TL7610/TL7612) or **☎** (TL7810/TL7812) on the headset to end a call. The switch hook presser pushes down the switch hook and ends the call.



Make and answer calls

Make and answer a call with a multi-line telephone and the handset lifter

Make a call:

1. Press **ON/OFF** (TL7610/TL7612) or **⏻** (TL7810/TL7812) on the headset. You hear a dial tone in the headset earpiece.
2. To change to a different telephone line, you need to select the line on your telephone.
3. Dial the telephone number using the telephone dialing keys.

Answer a call:

- Press **ON/OFF** (TL7610/TL7612) or **⏻** (TL7810/TL7812) on the headset to answer an incoming call.

The headset answers the telephone line that is ringing. If you are on a call and you receive a call on another telephone line, you cannot answer the new call from the headset.

End a call:

- Press **ON/OFF** (TL7610/TL7612) or **⏻** (TL7810/TL7812) on the headset to end a call.



NOTE: For complete instructions on using the cordless headsets, please refer to the manual provided with your TL7610/TL7612/TL7810/TL7812 product or you can download the manual from website. For TL7610/TL7612, visit **www.telephones.att.com/manuals** to download the manual. For TL7810/TL7812, visit **www.smbtelephones.att.com/smb** to download the manual from the **Product Support** page.

Troubleshooting

If you have difficulty with your handset lifter, please try the suggestions below. For customer service, visit our website at **www.telephones.att.com**, or call **1 (800) 222-3111**. In Canada, dial **1 (866) 288-4268**.

The switch hook presser doesn't rise at all.

- Make sure that **LIFTER MODE** light on the TL7610/TL7612 headset base is on, or the **CORDED HANDSET CONNECTED** switch is turned to **YES** on the TL7810/TL7812 headset base. Press the **MODE** button on the TL7610/TL7612 headset base, or the **PHONE/PC** button on the TL7810/TL7812 headset base to change the mode.
- Make sure the lifter control cable is securely plugged into the **LIFTER** jack on the TL7610/TL7612 headset base via the TL7610/TL7612 base adapter, or the **LIFTER** jack on the TL7810/TL7812 headset base.
- Make sure all cords and the telephone line cord are securely connected to the proper sockets.
- Make sure the headset base has power.
- Make sure your headsets are charged and registered to the headset base. For registration instructions, refer to the manual provided with your TL7610/TL7612/TL7810/TL7812 product, or you can download the manual from our website. For TL7610/TL7612, visit **www.telephones.att.com/manuals** to download the manual. For TL7810/TL7812, visit **www.smbtelephones.att.com/smb** to download the manual from the **Product Support** page.

When I press ON/OFF (TL7610/TL7612) or Ⓟ (TL7810/TL7812) on the headset, the handset lifter rises, but the call is not connected or I do not hear a dial tone.

- Try all the suggestions above.
- When using the handset lifter, make sure that TL7610/TL7612 headset base is set to **LIFTER MODE**, or the **CORDED HANDSET CONNECTED** switch is turned to **YES** on the TL7810/TL7812 headset base. Make sure the telephone line cord is connected to the telephone line jack on the back of the corded phone.

Troubleshooting

- The handset lifter may not rise high enough to release the switch hook. Try to adjust the height of the lifter arm by turning the **ADJUST LIFTER** knob until it reaches the desired angle. Adjust the switch hook presser by turning the switch hook presser adjustment knob so that the switch hook is released when the lifter arm rises.
- If you cannot hear a dial tone when the headset is on, you should adjust the quality of the corded handset audio first. During a call, slide the **LIFTER AUDIO ADJUST** switch at the side of the TL7610/TL7612 headset base from **A** to **G**, or the **LIFTER AUDIO ADJUST** switch at the bottom of the TL7810/TL7812 headset base from **A** to **F** until you obtain good sound quality.
- If the previous suggestions don't work, disconnect the telephone base from the telephone jack and connect a different telephone. If there is no dial tone on that telephone either, the problem is in your wiring or telephone service. Contact your telephone service provider.
- Your line cord might be defective. Install a new line cord.

My corded phone is ringing, but my headset is not ringing.

- Make sure that **LIFTER MODE** light on the TL7610/TL7612 headset base is on, or the **CORDED HANDSET CONNECTED** switch is turned to **YES** on the TL7810/TL7812 headset base. Press the **MODE** button on the TL7610/TL7612 headset base, or the **PHONE/PC** button on the TL7810/TL7812 headset base to change the mode.
- Make sure that the **RING ON/OFF** button on the lifter is turned on. If the **RING ON/OFF** button is turned off, the headset does not ring.
- If the speaker of your corded phone is not located under the lifter, install the auxiliary ring detector. See page 16 for instructions.
- It may be necessary to adjust the sensitivity level of the ring detector. See page 17 for instructions.
- If an auxiliary ring detector is used, make sure its cord is completely plugged into the handset lifter.

Troubleshooting

- Make sure all cords and the telephone line cord are plugged into the appropriate outlets.
- Make sure your headset is charged.

The other party cannot hear my voice during a call.

- Make sure your headset microphone is not muted.
- During a call, slide the **LIFTER AUDIO ADJUST** switch at the side of the TL7610/TL7612 headset base from **A** to **G**, or the **LIFTER AUDIO ADJUST** switch at the bottom of the TL7810/TL7812 headset base from **A** to **F** until you obtain good sound quality.

Nothing happens when I move the LIFTER AUDIO ADJUST switch.

- When the handset lifter is in use, make sure that **LIFTER MODE** light on the TL7610/TL7612 headset base is on, or the **CORDED HANDSET CONNECTED** switch is turned to **YES** on the TL7810/TL7812 headset base. Press the **MODE** button on the TL7610/TL7612 headset base, or the **PHONE/PC** button on the TL7810/TL7812 headset base to change the mode. Slide the **LIFTER AUDIO ADJUST** switch at the side of the TL7610/TL7612 headset base from **A** to **G**, or the **LIFTER AUDIO ADJUST** switch at the bottom of the TL7810/TL7812 headset base from **A** to **F** until you obtain good sound quality.

My headset is ringing even when there is no incoming call.

- The sensitivity level of your ring detector may be too high. See page 17 to adjust the sensitivity level.
- The ring detector may detect a sound from the environment and send a ring tone to the headset. See page 17 to turn off the ring detector.
- When you are using your telephone's speakerphone, the ring detector may send a ring tone to the headset. If you do not want the headset to ring, press the **RING ON/OFF** button to turn the ring detector off. After the call, you can press the **RING ON/OFF** button again to turn the ring detector back on.

Maintenance

Taking care of your handset lifter

- Your lifter contains sophisticated electronic parts, so it must be treated with care.
- Avoid rough treatment.
- Place the lifter down gently. Save the original packing materials to protect your lifter if you ever need to ship them.

Avoid water

- Your lifter can be damaged if it gets wet. Do not use the lifter outdoors in the rain, or handle it with wet hands. Do not install the lifter near a sink, bathtub or shower.

Electrical storms

- Electrical storms can sometimes cause power surges harmful to electronic equipment. For your own safety, take caution when using electric appliances during storms.

Cleaning your handset lifter

- Your lifter has a plastic casing with a metal motor enclosed. Disconnect all cables from the lifter before cleaning. Use only a soft cloth slightly dampened with water or mild soap. Do not clean the motor.
- Do not use excess water or cleaning solvents of any kind.

Remember that electrical appliances can cause serious injury if used when you are wet or standing in water. If the lifter should fall into water, DO NOT RETRIEVE IT UNTIL YOU UNPLUG THE POWER CORD AND TELEPHONE LINE CORDS FROM THE WALL, then pull the units out by the unplugged cords.

Important safety information



This symbol is to alert you to important operating or servicing instructions that may appear in this user's manual. Always follow basic safety precautions when using this product to reduce the risk of injury, fire, or electric shock.

Safety information

- **Read and understand all instructions in the user's manual. Observe all markings on the product.**
- **Avoid using this product during a thunderstorm.** There may be a slight chance of electric shock from lightning.
- **Do not use the headset to report a gas leak in the vicinity of the leak.** Under certain circumstances, a spark may be created when the adapter is plugged into the power outlet, or when the headset is replaced in its cradle. This is a common event associated with the closing of any electrical circuit. The user should not plug the headset base into a power outlet, and should not put a charged headset into the cradle, if the headset base is located in an environment containing concentrations of flammable or flame-supporting gases, unless there is adequate ventilation. A spark in such an environment could create a fire or explosion. Such environments might include: medical use of oxygen without adequate ventilation; industrial gases (cleaning solvents; gasoline vapors; etc.); a leak of natural gas; etc.
- **Do not use this product near water, or when you are wet.** For example, do not use the lifter in a wet basement or shower, or next to a swimming pool, bathtub, kitchen sink, or laundry tub. Do not use liquids or aerosol sprays for cleaning. If the product comes in contact with any liquids, unplug any line or power cord immediately. Do not plug the product back in until it is dried thoroughly.
- **Install this product in a protected location** where no one can trip over any line or power cords. Protect cords from damage or abrasion.
- **If this product does not operate normally, see the Troubleshooting section on pages 21-23 of this user's manual.** If you cannot solve the problem, or if the product is damaged, refer to the **Limited warranty** on pages 27-30. Do not open this product except as may be directed in your user's manual. Opening the product or reassembling it incorrectly may expose you to hazardous voltages or other risks.

FCC Part 15

This equipment has been tested and found to comply with the limits for a Class B digital device, pursuant to part 15 of the FCC Rules. These limits are designed to provide reasonable protection against harmful interference in a residential installation. This equipment generates, uses and can radiate radio frequency energy and, if not installed and used in accordance with the instructions, may cause harmful interference to radio communications. However, there is no guarantee that interference will not occur in a particular installation. If this equipment does cause harmful interference to radio or television reception, which can be determined by turning the equipment off and on, the user is encouraged to try to correct the interference by one or more of the following measures:

- Reorient or relocate the receiving antenna.
- Increase the separation between the equipment and receiver.
- Connect the equipment into an outlet on a circuit different from that to which the receiver is connected.
- Consult the dealer or an experienced radio/TV technician for help.

Changes or modifications to this equipment not expressly approved by the party responsible for compliance could void the user's authority to operate the equipment.

This device complies with Part 15 of the FCC Rules. Operation is subject to the following two conditions: (1) this device may not cause harmful interference, and (2) this device must accept any interference received, including interference that may cause undesired operation.

This Class B digital apparatus complies with Canadian ICES-003.

Limited warranty

The AT&T brand is used under license - any repair, replacement or warranty service, and all questions about this product should be directed to:

In the United States of America, visit

www.telephones.att.com or call **1 (800) 222-3111**.

In Canada, call **1 (866) 288-4268**.

1. What does this limited warranty cover?

The manufacturer of this AT&T branded product warrants to the holder of a valid proof of purchase (“CONSUMER” or “you”) that the product and all accessories provided in the sales package (“PRODUCT”) are free from defects in material and workmanship, pursuant to the following terms and conditions, when installed and used normally and in accordance with the PRODUCT operating instructions. This limited warranty extends only to the CONSUMER for products purchased and used in the United States of America and Canada.

2. What will be done if the PRODUCT is not free from defects in materials and workmanship during the limited warranty period (“materially defective PRODUCT”)?

During the limited warranty period, the manufacturer’s authorized service representative will repair or replace at the manufacturer’s option, without charge, a materially defective PRODUCT. If the manufacturer repairs the PRODUCT, they may use new or refurbished replacement parts. If the manufacturer chooses to replace the PRODUCT, they may replace it with a new or refurbished PRODUCT of the same or similar design. The manufacturer will retain defective parts, modules, or equipment. Repair or replacement of the PRODUCT, at the manufacturer’s option, is your exclusive remedy. The manufacturer will return repaired or replacement products to you in working condition. You should expect the repair or replacement to take approximately 30 days.

Limited warranty

3. How long is the limited warranty period?

The limited warranty period for the PRODUCT extends for ONE (1) YEAR from the date of purchase. If the manufacturer repairs or replaces a materially defective PRODUCT under the terms of this limited warranty, this limited warranty also applies to repaired or replacement PRODUCT for a period of either (a) 90 days from the date the repaired or replacement PRODUCT is shipped to you or, (b) the time remaining on the original one-year limited warranty; whichever is longer.

4. What is not covered by this limited warranty?

This limited warranty does not cover:

- PRODUCT that has been subjected to misuse, accident, shipping or other physical damage, improper installation, abnormal operation or handling, neglect, inundation, fire, water, or other liquid intrusion; or
- PRODUCT that has been damaged due to repair, alteration, or modification by anyone other than an authorized service representative of the manufacturer; or
- PRODUCT to the extent that the problem experienced is caused by signal conditions, network reliability or cable or antenna systems; or
- PRODUCT to the extent that the problem is caused by use with non-AT&T accessories; or
- PRODUCT whose warranty/quality stickers, PRODUCT serial number plates or electronic serial numbers have been removed, altered or rendered illegible; or
- PRODUCT purchased, used, serviced, or shipped for repair from outside the United States of America or Canada, or used for commercial or institutional purposes (including but not limited to products used for rental purposes); or
- PRODUCT returned without a valid proof of purchase (see item 6 below); -or-
- Charges for installation or setup, adjustment of customer controls, and installation or repair of systems outside the unit.

Limited warranty

5. How do you get warranty service?

To obtain warranty service in the United States of America, visit **www.telephones.att.com** or call **1 (800) 222-3111**. In Canada, call **1 (866) 288-4268**.

NOTE: Before calling for service, please review the user's manual; a check of the PRODUCT's controls and features may save you a service call.

Except as provided by applicable law, you assume the risk of loss or damage during transit and transportation and are responsible for delivery or handling charges incurred in the transport of the PRODUCT(s) to the service location. The manufacturer will return repaired or replaced PRODUCT under this limited warranty to you. Transportation, delivery or handling charges are prepaid. The manufacturer assumes no risk for damage or loss of the PRODUCT in transit. If the PRODUCT failure is not covered by this limited warranty, or proof of purchase does not meet the terms of this limited warranty, the manufacturer will notify you and will request that you authorize the cost of repair prior to any further repair activity. You must pay for the cost of repair and return shipping costs for the repair of products that are not covered by this limited warranty.

6. What must you return with the PRODUCT to get warranty service?

You must:

- a. Return the entire original package and contents including the PRODUCT to the service location along with a description of the malfunction or difficulty; and
- b. Include a "valid proof of purchase" (sales receipt) identifying the PRODUCT purchased (PRODUCT model) and the date of purchase or receipt; and
- c. Provide your name, complete and correct mailing address, and telephone number.

Limited warranty

7. Other limitations

This warranty is the complete and exclusive agreement between you and the manufacturer of this AT&T branded PRODUCT. It supersedes all other written or oral communications related to this PRODUCT. The manufacturer provides no other warranties for this PRODUCT. The warranty exclusively describes all of the manufacturer's responsibilities regarding the PRODUCT. There are no other express warranties. No one is authorized to make modifications to this limited warranty and you should not rely on any such modification.

State/Provincial Law rights: This warranty gives you specific legal rights, and you may also have other rights which vary from state to state or province to province.

Limitations: Implied warranties, including those of fitness for a particular purpose and merchantability (an unwritten warranty that the PRODUCT is fit for ordinary use) are limited to one year from date of purchase. Some states/provinces do not allow limitations on how long an implied warranty lasts, so the above limitation may not apply to you. In no event shall the manufacturer be liable for any indirect, special, incidental, consequential, or similar damages (including, but not limited to lost profits or revenue, inability to use the PRODUCT or other associated equipment, the cost of substitute equipment, and claims by third parties) resulting from the use of this PRODUCT. Some states/provinces do not allow the exclusion or limitation of incidental or consequential damages, so the above limitation or exclusion may not apply to you.

Please retain your original sales receipt as proof of purchase.

A

- AC adapter 4, 8, 10
- Adjust
 - corded handset audio 6, 11
 - height of the lifter arm 13
 - sensitivity level 17
 - switch hook presser
 - position 13
- Answer a call 19, 20
- Anti-slip pad 15
- Attach lifter 12
- Auxiliary ring detector
 - installation 16
 - sensitivity adjust 17

B

- Base adapter 4, 5, 8, 10

C

- Corded handset audio
 - adjust switch 6
- Corded handset
 - connected switch 8, 10
- Corded phone
 - connection 4, 7, 9

D

- Dial tone 6, 13, 14, 19, 20
- DSL 4, 7, 9

E

- End a call 19, 20

H

- Headset base 4, 7, 9

I

- Install
 - auxiliary ring detector 16
 - headset base 3-11
- Internal ring detector 16

L

- Large lifter pad 15
- Limited warranty 27-30

M

- Maintenance 24
- Make a call 19, 20
- Multi-line telephone 20

R

- Ring detector 16-18

S

- Safety information 25
- Small lifter pad 15
- Status light 18
- Switch hook presser 13, 19

T

- Troubleshooting 21-23

U

- USB port 10



www.telephones.att.com