



at&t

## Quick start guide

**TL92271/TL92371/TL92471**  
**DECT 6.0 cordless telephone/  
answering system with  
BLUETOOTH® wireless technology**



# Installation

You must install and charge the handset battery before using the cordless handset.



See page 3 for easy instructions.

Install the telephone base close to a telephone jack and a power outlet not controlled by a wall switch. The telephone base can be placed on a flat surface or vertically mounted on the wall. For optimum range and better reception, place the telephone base in a central and open location.

You may hear interference if your cellular phone is too close to the telephone base during a **CELLULAR** call. Make sure that your Bluetooth enabled cellular phone is within 15 feet of the telephone base in order to maintain a clear and consistent connection between your Bluetooth cell phone, telephone base and cell tower.

If you subscribe to high-speed Internet service (digital subscriber line - DSL) through your telephone line, you must install a DSL filter between the telephone line cord and the telephone wall jack (page 2). The filter prevents noise and caller ID problems caused by DSL interference. Please contact your DSL service provider for more information about DSL filters.

Your product may be shipped with a protective sticker covering the handset or telephone base display - remove it before use.

For customer service or product information, visit our website at **[www.telephones.att.com](http://www.telephones.att.com)** or call **1 (800) 222-3111**. In Canada, dial **1 (866) 288-4268**.

## **Avoid placing the telephone base too close to:**

- Communication devices such as television sets, VCRs, or other cordless telephones.
- Excessive heat sources.
- Noise sources such as a window with traffic outside, motors, microwave ovens, refrigerators, or fluorescent lighting.
- Excessive dust sources such as a workshop or garage.
- Excessive moisture.
- Extremely low temperature.
- Mechanical vibration or shock such as on top of a washing machine or work bench.

# Telephone base and charger installation

If you subscribe to high-speed Internet service (digital subscriber line - DSL) through your telephone line, you must install a DSL filter between the telephone line cord and the telephone wall jack. The filter prevents noise and caller ID problems caused by DSL interference. Please contact your DSL service provider for more information about DSL filters.

Follow the steps below to install the telephone.

## Telephone base installation

---

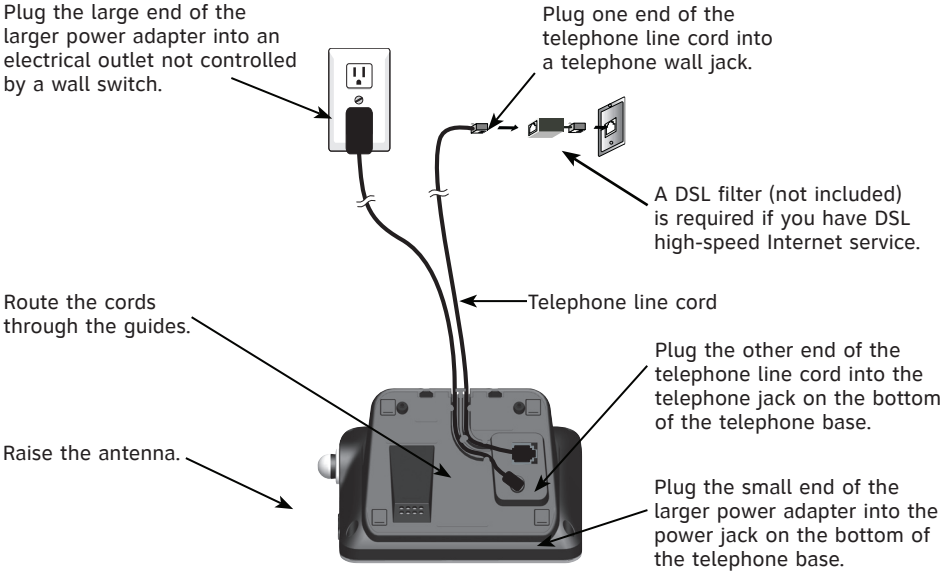

## Telephone base installation

---

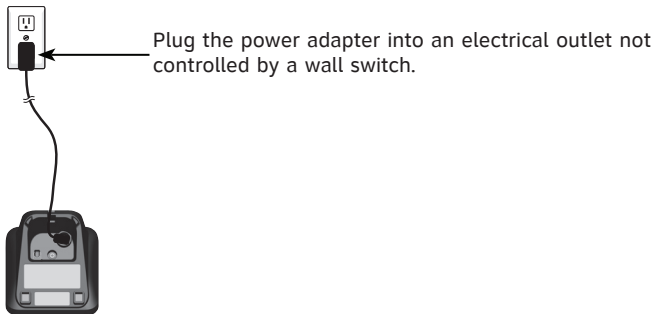

### IMPORTANT INFORMATION:

1. Use only the power adapter(s) provided with this product. To obtain a replacement, visit our website at [www.telephones.att.com](http://www.telephones.att.com) or call **1 (800) 222-3111**. In Canada, dial **1 (866) 288-4268**.
2. The power adapters are intended to be correctly oriented in a vertical or floor mount position. The prongs are not designed to hold the plug in place if it is plugged into a ceiling, under-the-table or cabinet outlet.

# Battery installation and charging

Install the battery as shown below.



## Step 1

Plug the battery connector securely into the socket inside the handset battery compartment, matching the color-coded label. Insert the supplied battery with the label **THIS SIDE UP** facing up as indicated.



## Step 2

Align the cover flat against the battery compartment, then slide it upwards until it clicks into place.



## Step 3

Charge the handset by placing it face up in the telephone base or charger. The **CHARGE** light is on when charging.

After you install your telephone or power returns following a power outage, the handset will prompt you to set the date and time. For instructions, see **Set date and time** on page 9. To skip setting the date and time, press **OFF/CANCEL** or **BACK**.



## IMPORTANT INFORMATION:

- Use only the supplied rechargeable battery or replacement battery (model BT166342). To order, visit our website at **www.telephones.att.com** or call **1 (800) 222-3111**. In Canada, dial **1 (866) 288-4268**.
- If you do not use the handset for a long time, disconnect and remove the battery to prevent possible leakage.

# Quick reference guide - handset

## **CHARGE** light

On when the handset is charging in the telephone base or charger.

## **Softkeys (2)**

Press to select a menu item displayed above the key.

While in a menu, press to select an item or save an entry or setting.

## **CELLULAR**

Press to make or answer a cell call.

During a cell call, press to answer an incoming call when you hear a call waiting alert.

Flashes quickly when there is an incoming cell call.

Flashes slowly when a cell call is on hold.

## **HOME/FLASH**

Press to make or answer a home call.

During a home call, press to answer an incoming call when you hear a call waiting alert.

Flashes quickly when there is an incoming home call.

Flashes slowly when a home call is on hold.

## **1**

While reviewing a caller ID history entry, press repeatedly to add or remove **1** in front of the telephone number before dialing or saving it in a directory.

## **tone X**

Press to switch to tone dialing temporarily during a call if you have pulse service.

Press to toggle the name order when saving a caller ID log entry into a directory.

## **SPEAKER**

Press to make or answer a home or cell call using the speakerphone.

Press to turn on the handset speakerphone.

Press again to resume normal handset use.

## **REDIAL/PAUSE**

Press repeatedly to view the last 10 numbers dialed.

While entering numbers, press and hold to insert a dialing pause.



# Quick reference guide - handset

**DIR▲/VOLUME**  
Press to scroll up while in menus.  
During a call or message playback, press to increase the listening volume.  
Press to show directory entries when the telephone is not in use.  
While entering names or numbers in the directory, press to move the cursor to the left.

**MUTE/DELETE**  
During a call, press to mute the microphone.  
While predialing, press to delete digits.  
While reviewing the redial list, directory or caller ID history, press to delete an individual entry.  
While entering or editing a directory entry, press to erase a digit or character.  
While the handset is ringing, press to silence the ringer temporarily.  
During message or announcement playback, press to delete a message or announcement.

**OFF/CANCEL**  
While using menus, press to cancel an operation, back up to the previous menu, or exit the menu display.  
Press and hold to return to idle mode.  
During a call, press to hang up.  
Press and hold while the telephone is not in use to erase the displayed messages (**XX Missed calls** and **Download fail**).  
While the handset is ringing, press to silence the ringer temporarily.

**CID▼/VOLUME**  
Press to scroll down while in menus.  
During a call or message playback, press to decrease the listening volume.  
Press to show the caller ID history when the telephone is not in use.  
While entering names or numbers in the directory, press to move the cursor to the right.

**# (pound key)**  
Press repeatedly to display other dialing options when reviewing a caller ID history entry.

**EQ**  
During an outside call, intercom call, message or announcement playback, press to change the quality of the audio to best suit your hearing.

# Quick reference guide - handset



## PUSH TO TALK

Press to begin a one-to-one or one-to-group broadcast.

Press and hold to begin a one-to-group broadcast when the handset is not in use.

## Main menu

The selected menu item is highlighted.



## Feature menu

- Play messages
- Answering sys
- Directory
- Caller ID log
- Intercom
- Bluetooth
- Ringers
- Set date/time
- Settings
- Website

## Using menus

1. Press **MENU** in idle mode (when the telephone is not in use) to enter the main menu.
2. Use **CID**▼ or **▲DIR** to scroll through menu items.
3. Press **SELECT** to select or save the highlighted item.

**-OR-**

Press **OFF/CANCEL** to cancel an operation, back up to the previous menu, or exit the menu display.

**-OR-**

Press and hold **OFF/CANCEL** to return to idle mode.

# Quick reference guide - telephone base

## ⏻/ANS ON

Press to turn the answering system on or off.

## 📞/HANDSET LOCATOR

Press to page all system handsets.

## ⏮/REPEAT

Press to repeat a message or press twice to play the previous message.

## ▶/PLAY/STOP

Press to play messages.  
Press to stop message playback.

## ✖/DELETE

Press to delete the message currently playing.  
When the phone is not in use, press twice to delete all previously reviewed messages.

## ▶▶/SKIP

Press to skip to the next message.



## Message counter

Number of messages (or during playback, message number currently playing).

## IN USE light

On when the handset is in use, when the answering system is answering an incoming call, or when you are registering a handset.

Flashes when another telephone is in use on the same line, or when you are deregistering handsets from the telephone base.

Flashes quickly when there is an incoming home call.

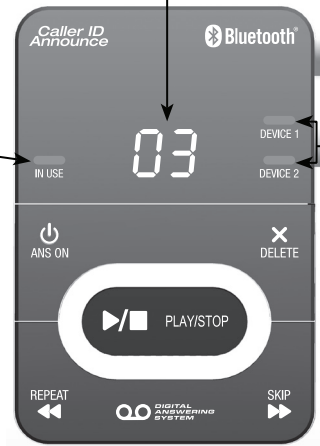

## DEVICE1/DEVICE2 lights

On when the telephone base is paired and connected with a Bluetooth device.

Flash alternately while pairing with a Bluetooth device.

Flashes quickly when there is an incoming cell call.



## Quick reference guide - telephone base

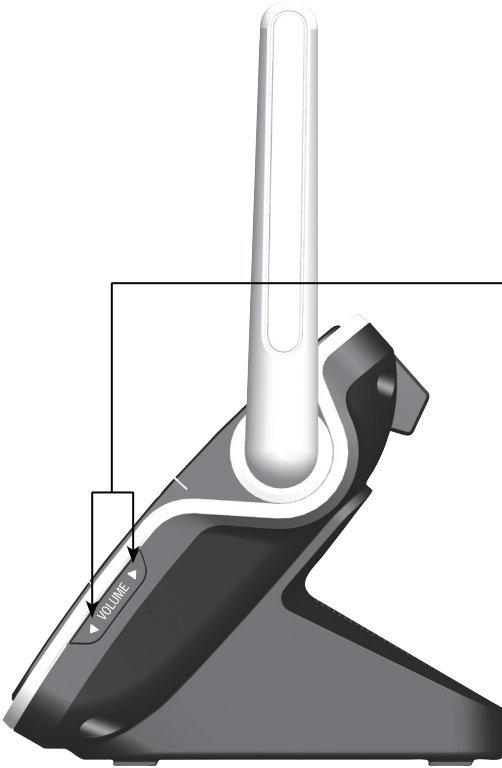

### ▼ VOLUME ▲

Press to adjust the volume during message playback.

When the phone is not in use, press to adjust the telephone base ringer volume.

# Telephone settings

## Set date and time

### To set the date and time manually:

1. Press **MENU** on the handset in idle mode to enter the main menu.
2. Press **CID▼** or **▲DIR** to highlight **Set date/time**, then press **SELECT**.
3. Press **CID▼** or **▲DIR** to select the month, then press **SET**, or enter the two-digit number (**01-12**) using the dialing keys (**0-9**).
4. Press **CID▼** or **▲DIR** to select the day, then press **SET**, or enter the two-digit number (**01-31**) using the dialing keys (**0-9**).
5. Press **CID▼** or **▲DIR** to select the year, then press **SET**, or enter the two-digit number (**00-99**) using the dialing keys (**0-9**), then press **SET**.
6. Press **CID▼** or **▲DIR** to select the hour, then press **SET**, or enter the two-digit number (**01-12**) using the dialing keys (**0-9**).
7. Press **CID▼** or **▲DIR** to select the minute, then press **SET**, or enter the two-digit number (**00-59**) using the dialing keys (**0-9**).
8. Press **CID▼** or **▲DIR** to highlight **AM** or **PM**, or press **2** for **AM** or **7** for **PM**. Press **SET** to save. You hear a confirmation tone.



**i** **NOTE:** If the date and time are not set when a message is recorded, the system announces, "Time and day not set," before each message plays.

## Caller ID announce

By default, the caller ID feature is programmed **On**.

### To turn on/off the caller ID announce on your handset:

1. Press **MENU** on the handset in idle mode to enter the main menu.
2. Press **CID▼** or **▲DIR** to highlight **Settings**, then press **SELECT**.
3. Press **CID▼** or **▲DIR** to highlight **Caller ID Annc**, then press **SELECT**.
4. Press **CID▼** or **▲DIR** to highlight **Handset** or **Base**, then press **SELECT**.
5. Press **CID▼** or **▲DIR** to choose **On** or **Off**, then press **SET** to save. You hear a confirmation tone.



### **i** **NOTES:**

- See your user's manual for complete instructions on using all features of this telephone.
- Pronunciation of names may vary with this feature. Not all names may be pronounced correctly.

# Bluetooth setup

To use a Bluetooth enabled cellular phone with your telephone, you must first pair and connect your Bluetooth cellular phone with the telephone base. All **TL92271/TL92371/TL92471** handsets can be used to make or answer calls on the cell phone line.

Bluetooth wireless technology operates within a short range (up to 30 feet). When you pair a Bluetooth cell phone or Bluetooth headset to the telephone base, keep the device within 15 feet of the telephone base for optimal performance.

## Add a cell phone

---

Before you begin, make sure that you have cellular coverage and your Bluetooth enabled cell phone is not connected to any other Bluetooth device. Refer to your cell phone user's manual to learn how to search for or add new Bluetooth devices.

### To pair and connect a cell phone:

1. Press **MENU** in idle mode to enter the main menu.
2. Press **CID** or **▲DIR** to highlight **Bluetooth**, then press **SELECT**.
3. Press **SELECT** to choose **Add device**.
4. Press **SELECT** again to choose **Add cellular**. The screen displays **Please wait...** followed by **1. If cell is connected to BT device, please disconnect it.**
  - If there are already four paired devices on the device list, the 4th device on the device list will be automatically removed, regardless of whether the new device pairing is successful or not.
  - If there are already two active devices on the device list with prefix **D1:** or **D2:**, the handset shows **Only 2 devices can be ready for connection.** You are prompted to deactivate an active device.
5. Press **NEXT**. The screen displays **2. Place cell phone next to base.**
  - All devices that are connected to the telephone base are disconnected until the pairing process is completed.
6. Press **NEXT** to turn on the telephone base discoverable mode. The screen displays **Set cell to search base: AT&T DECT 6.0 discoverable PIN: 0000**. Promptly turn on the Bluetooth feature of your cell phone and search for or add new devices.



# Bluetooth setup

7. Your cell phone may require a passcode. In this case the handset screen displays **Check cellular. ENTER PASS CODE**. Enter the cell phone passcode into the handset and press **SET** to save.
8. Enter the PIN of the telephone base (the default PIN is **0000**) into your cell phone to continue the pairing process. The handset displays **Adding Cell Phone A to device list...**
9. When a device is successfully connected, the handset displays **Cell Phone A is added and connected to base.** You hear a confirmation tone. The corresponding status icon (**1** or **2**) displays. The corresponding device light on the telephone base (**DEVICE 1** or **DEVICE 2**) turns on.

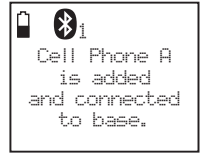

## NOTES:

- The pairing process may take up to one minute. If the pairing process fails, try again.
- If you put the handset back in the telephone base or charger while pairing, the process is cancelled and the handset returns to idle mode.
- If a device fails to connect, the handset displays **Headset A is added into the device list**, and then displays **Please use headset to connect to base.**

# Bluetooth setup

## Add a headset

Before you begin, make sure that your Bluetooth enabled headset is not connected to any other Bluetooth device. Refer to your headset user's manual to learn how to search for or add new Bluetooth devices.

### To pair and connect a headset:

1. Press **MENU** on the handset in idle mode to enter the main menu.
2. Press **CID** or **▲DIR** to highlight **Bluetooth**, then press **SELECT**.
3. Press **SELECT** to choose **Add device**.
4. Press **CID** or **▲DIR** to highlight **Add headset**, then press **SELECT**. The screen displays **Please wait...** followed by **If headset is connected to cell, please disconnect it.**
  - If there is another headset already active, the screen shows **Only 1 headset in device list can be ready for connection** and prompt you to replace an existing paired device (page 17).
  - When you already have two active devices, the handset shows **Only 2 devices can be ready for connection.** The telephone base will deactivate another headset from an active slot automatically.
5. Press **NEXT**. The screen displays **Pls set headset to discoverable mode.** Set your headset to discoverable mode (refer to the user's manual of your headset), then press **NEXT**.
  - All devices that are connected to the telephone base are temporarily disconnected.
6. The screen displays **Searching for Bluetooth headsets...**
7. When the screen displays the found devices, press **CID** or **▲DIR** to highlight your headset and then press **SELECT**.
8. Enter the PIN of your headset. The PIN for most Bluetooth devices is **0000** (refer to the user's manual of your headset). Then press **NEXT**.



# Bluetooth setup

9. The screen displays **Adding Headset A to device list...** when the base is connecting to your headset.



10. When a device is successfully connected, the handset displays **Headset A is added and connected to base** and the corresponding status icon (Ⓜ1 or Ⓜ2). You hear a confirmation tone. The corresponding light on the telephone base (**DEVICE 1** or **DEVICE 2**) turns on.

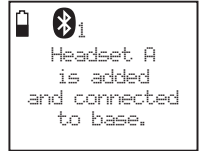

## NOTES:

- The pairing process may take up to one minute. If the pairing process fails, try again.
- If you put the handset back in the telephone base or charger while pairing, the process discontinues and the handset returns to idle mode.
- If a device fails to connect, the handset displays **Headset A is added into the device list**, and then displays **Please use headset to connect to base**.

## **Auto connection**

---

An active device may be disconnected from the telephone base when:

- The Bluetooth feature of your cell phone is turned off.
- The power of your device is turned off.
- Your Bluetooth device are not is not within range of the telephone base.

When the Bluetooth or power on the device is turned on or it moves within range of the base, the base will try to reconnect to the Bluetooth device. If you disconnect the device through the device list, the base will not attempt to reconnect unless your device is moved out of range and then goes back in range again.

# Bluetooth setup

## Device list and connection

---

Up to four devices can be paired to the telephone base. All paired devices are shown on the device list. To use a paired device, it must be connected and in an active slot (**DEVICE 1** or **DEVICE 2**) on the device list. Only one Bluetooth cell phone or a headset can be on a call at a time.

Once you have paired a device with the telephone base, you do not need to repeat the pairing procedure again unless you delete the device from the device list.

**i NOTE:** When connecting a Bluetooth device to the device list, all connected devices will be temporarily disconnected until the procedure is complete. It may take up to two minutes to reconnect.

## Review the active device list

---

1. Press **MENU** on the handset when it is not in use.
2. Press **CID** or **▲DIR** to highlight **Bluetooth**, then press **SELECT**.
3. Press **CID** or **▲DIR** to highlight **Device list**, then press **SELECT**.

## Connect/disconnect an active device

---

While in the active devices menu, you may connect or disconnect your active device.

1. Press **MENU** on the handset when it is not in use.
2. Press **CID** or **▲DIR** to highlight **Bluetooth**, then press **SELECT**.
3. Press **CID** or **▲DIR** to highlight **Device list**, then press **SELECT**.
4. Press **CID** or **▲DIR** to highlight a device, then press **OPTION**.
5. Press **CID** or **▲DIR** to highlight **Connect/Disconnect** (whichever is applicable), then press **SELECT** to confirm. The handset displays **Device connected/Device disconnected**. You hear a confirmation tone.

**i NOTE:** When your active device is connected, you are prompted to select **Disconnect**. When your active device is disconnected, you are prompted to select **Connect**.

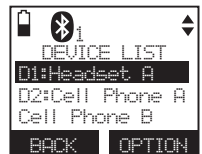

# Bluetooth setup

## Remove a device

---

When you already have the maximum of four paired devices on the device list and you want to add another device, you must first delete a device from the device list.

### To remove a device:

1. Press **MENU** on the handset in idle mode to enter the main menu.
2. Press **CID** or **DIR** to highlight **Bluetooth**, then press **SELECT**.
3. Press **CID** or **DIR** to highlight **Device list**, then press **SELECT**.
4. Press **CID** or **DIR** to highlight a selected device, then press **MUTE/DELETE**.

-OR-

- Press **CID** or **DIR** to highlight a selected device, then press **OPTION**.
  - Press **CID** or **DIR** to highlight **Remove**, then press **SELECT**.
5. The handset displays **Remove Headset A?** Press **YES** to confirm. The handset displays **Device removed from device list**. You hear a confirmation tone.

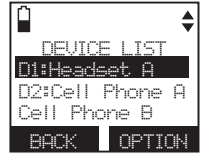



# Bluetooth setup

## Rename a device

You can change the name of a paired device on the paired devices list.

1. Press **MENU** on the handset when it is not in use.
2. Press **CID▼** or **▲DIR** to highlight **Bluetooth**, then press **SELECT**.
3. Press **CID▼** or **▲DIR** to highlight **Device list**, then press **SELECT**.
4. Press **CID▼** or **▲DIR** to highlight a device when necessary, then press **OPTION**.
5. Press **CID▼** or **▲DIR** to highlight **Rename**, then press **SELECT**. The screen displays **ENTER NEW NAME**.
6. Use the dialing keys to edit the name.
  - Press **MUTE/DELETE** to erase a character.
  - Press and hold **MUTE/DELETE** to erase all characters.
  - Press **CID▼** or **▲DIR** to move the cursor to the right or left.
7. Press **SAVE**. The handset displays **Device renamed**. You hear a confirmation tone.

**i** **NOTE:** Only the first 11 characters of the device name are shown on the device list.

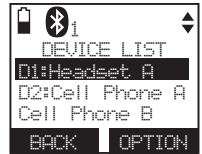

# Bluetooth setup

## Replace an active device

If you already have two active devices on the device list and you want to activate a different device, you must deactivate one of the two active devices.

### To replace an active device:

1. Press **MENU** on the handset when it is not in use.
2. Press **CID▼** or **▲DIR** to highlight **Bluetooth**, then press **SELECT**.
3. Press **CID▼** or **▲DIR** to highlight **Device list**, then press **SELECT**.
4. Press **CID▼** or **▲DIR** to highlight the device you want to activate, without a prefix **D1:** or **D2:**, then press **OPTION**.
5. Press **CID▼** or **▲DIR** to highlight **Connect**, then press **SELECT**. The handset displays **Only 2 devices can be ready for connection** and then a list of devices for deactivation.
6. Press **CID▼** or **▲DIR** to highlight the device to be deactivated, then press **NEXT**. The handset displays **Cell Phone A is deactivated** and you hear a confirmation tone. The screen then displays **Connecting Cell Phone B to the base...**
7. Depending on your cell phone settings, you may need to press a key on your cell phone to confirm the connection. When the new device is successfully activated and connected, the handset displays **Device connected**. You hear a confirmation tone.

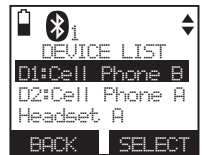
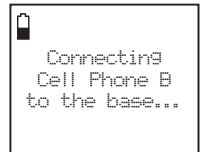
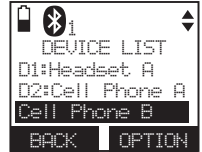

## Bluetooth connection from idle mode

When you have active devices that are not connected, **CONNECT** appears on the idle handset. Press **CONNECT** to start connecting an active device. When there are two active devices, the handset will prompt you to choose one before connection.



# Bluetooth setup

## Download directory

You can download up to four cell phone directories (phonebooks) to your **TL92271/TL92371/TL92471** telephone system via Bluetooth wireless technology. Each downloaded directory can store up to 1,500 entries with up to 30 digits for each phone number and 15 characters for each name.

Before downloading a directory, make sure the cell phone is paired, active, and connected to your **TL92271/TL92371/TL92471**. Make sure the handset battery is charged for at least 30 minutes.

**Place your cell phone next to the telephone base when you download a cell phone directory to your TL92271/TL92371/TL92471.**

### To download a cell phone directory:

1. Press **MENU** on the handset when it is not in use.
2. Press **CID** or **▲DIR** to highlight **Bluetooth**, then press **SELECT**.
3. Press **CID** or **▲DIR** to highlight **Download dir**, then press **SELECT**.
  - If there is no cell phone paired to the system, the handset displays **Device list is empty**. Press **OK** to return to the Bluetooth menu.
4. Press **CID** or **▲DIR** to select a desired device, then press **SELECT**.
  - If the selected device is active but disconnected, the handset displays **Cellular phone not connected**. Press **CONNECT**.
5. Press **CID** or **▲DIR** to highlight one of the following options:
  - **Phone memory** - download all contacts stored in your phone memory.
  - **SIM card only** - download all contacts stored in your SIM card.
  - **Phone and SIM** - download all contacts stored in both your phone memory and SIM card.

Press **SELECT**. During the download, the handset displays the progress. All other idle system handsets display **Downloading dir**.

- Your cell phone may require a passcode. In this case the screen displays **Check cellular. ENTER PASS CODE**. Enter the cell phone passcode into the handset and press **SET** to save.

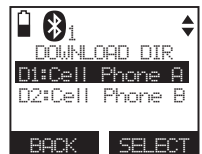

## Bluetooth setup

- If the selected device's directory has already been downloaded to **TL92271/TL92371/TL92471** before, the handset displays the date of the last download from your cell phone. The directory stored on the **TL92271/TL92371/TL92471** for that cell phone will be erased and replaced with the current cell phone directory. If you have edited the downloaded entries, those changes will be lost. Press **NEXT** to start the download, the screen displays **Erasing directory...**
  - If you already have four downloaded directories, the handset displays **Memory is full. Replace existing directory?** Press **YES** if you want to replace an existing directory. Highlight the cell phone directory to be replaced and press **SELECT**. The screen displays **Replace Cell Phone A directory?** Press **YES** to confirm.
6. When the downloading process is complete, the handset displays **Download ended XXXX entries saved**. You hear a confirmation tone. Press **OK** to return to the download directory menu.

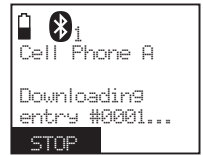
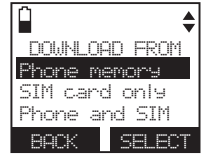

### **i**NOTES:

- With certain cell phones, downloading from the SIM card is not supported. If this is the case, try transferring the contacts from your SIM card to your cell phone memory first, then download from your cell phone memory. For more information on how to transfer contacts from your SIM card to your cell phone memory, see the user's manual of your cell phone.
- If **Phone memory** is chosen but with no entries saved, the handset displays **No entries found. Download from SIM only?** Press **YES** to confirm. If **SIM card only** is chosen but with no entries saved, the handset displays **No entries found. Download from Phone only?** Press **YES** to confirm. If **Phone and SIM** are chosen but with no entries saved in either or both directories, the handset display **No entries found. Download from Phone only?** Press **YES** to confirm.
- When downloading the directory from your Bluetooth enabled cell phone, some data may not transfer. For example, if you have home, mobile and work numbers for a particular contact, the three categories may not transfer to your **TL92271/TL92371/TL92471**.
- On certain cell phones, you may need to press a key to confirm the directory download.

# Bluetooth setup

## Interruption to directory download

---

If you are downloading a directory from a cell phone and the phone receives a call, the download process stops and all handsets display **Download fail**. When you try to view the downloaded directory, the handset displays **Last download failed: MM/DD/YY**. You need to download the directory again (see page 18).

If you are downloading a directory from a cell phone and the telephone base loses power, the download process stops. When the telephone base regains power, the handset only displays the **Home** directory. You need to download the directory again (see page 18).

The download process continues even if any of the following occur:

- You place the handset in the telephone base or charger.
- You access your cell phone menu features.
- The handset battery becomes depleted or the handset loses connection with the telephone base.

**iNOTE:** During the download process, do not attempt to make changes to your cell phone directory.

## View the directory download information

---

1. Press **MENU** on the handset in idle mode to enter the main menu.
2. Press **CID** or **▲DIR** to highlight **Directory**, then press **SELECT**.
3. Press **CID** or **▲DIR** to choose the desired downloaded directory, then press **OPTION**.
4. Press **CID** or **▲DIR** to highlight **Last update**, then press **SELECT**. The directory download information appears on the screen. Press **OK** to exit.

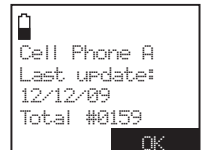

# Bluetooth setup

## Change PIN

---

You are required to enter a PIN when establishing a Bluetooth connection. The default PIN of your telephone base is **0000**.

### To change the PIN:

1. Press **MENU** on the handset in idle mode to enter the main menu.
2. Press **CID▼** or **▲DIR** to highlight **Bluetooth**, then press **SELECT**.
3. Press **CID▼** or **▲DIR** to highlight **Change PIN**, then press **SELECT**. The handset displays **ENTER NEW PIN** and the existing PIN.
4. Use the dialing keys to enter a new four-digit code.
  - Press **MUTE/DELETE** to erase a digit.
  - Press and hold **MUTE/DELETE** to erase all digits.
  - Press **CID▼** or **▲DIR** to move the cursor to the right or left.
5. Press **SET** to save. You hear a confirmation tone.

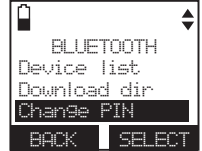

# Making, answering and ending a call

## Make, answer or end a home call

---

### To make a home call:

- Press **HOME/FLASH** or **SPEAKER**, then enter the telephone number.

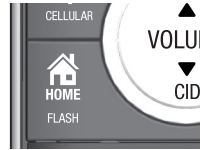

### To answer a home call:

- Press **HOME/FLASH** or **SPEAKER**.

### To end a home call:

- Press **OFF/CANCEL** or put the handset in the telephone base or charger.



### **i**NOTES:

- The screen shows the elapsed time as you talk (in hours, minutes and seconds).
- You cannot answer a home call using your connected cell phone.

## Make, answer or end a cell call

---

### To make a cell call:

- Enter the telephone number, then press **CELLULAR**.

### To answer a cell call:

- Press **CELLULAR**.

**i****NOTE:** You can also use your cell phone to answer the call. If you answer with your cell phone, it disconnects from the telephone base.

### To end a cell call:

- Press **OFF/CANCEL** or put the handset in the telephone base or charger.

# Answering system settings

## Turn the answering system on or off

When the answering system is turned on, the **ANS ON** light on the telephone base is on and the handsets display **ANS ON**.

### To turn the answering system on or off:

#### Using the telephone base:

Press **ANS ON** to turn the answering system on or off. When the answering system is turned on, it announces, **“Calls will be answered.”** When the answering system is turned off, it announces, **“Calls will not be answered.”**

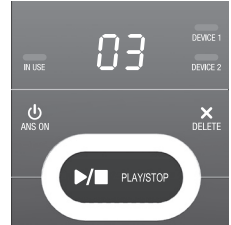

#### Using a handset:

1. Press **MENU** on the handset in idle mode to enter the main menu.
2. Press **CID** or **DIR** to highlight **Answering sys**, then press **SELECT**.
3. Press **CID** or **DIR** to highlight **Answer ON/OFF**, then press **SELECT**.
4. Press **CID** or **DIR** to highlight **On** or **Off**, then press **SET** to save. You hear a confirmation tone.

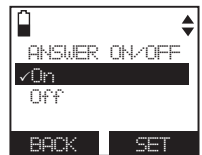
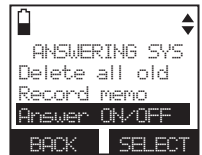



# Answering system settings

## Record your own announcement

1. Press **MENU** on the handset in idle mode to enter the main menu.
2. Press **CID** or **DIR** to scroll to **Answering sys**, then press **SELECT**.
3. Press **SELECT** again to select **Announcement**.
4. The handset displays **ANNOUNCEMENT**. Press **RECORD**.
5. The handset announces, "Record after the tone. Press **STOP** when you are done." After the tone, speak towards the microphone of the handset.
6. Press **STOP** when you finish recording.
7. The handset automatically plays back the newly recorded announcement. Press **STOP** to stop the playback at any time. After the announcement playback, press **PLAY** to replay the recorded announcement, or **RECORD** to record again if desired.

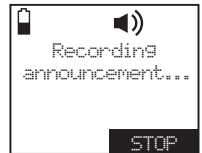
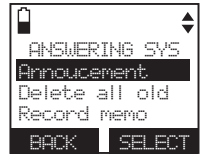

# Message playback

## Listen to messages with the telephone base

Press ►/■/PLAY/STOP to listen to messages. The system announces the number of messages, then begins playback.

### Options during playback:

- Press ▼VOLUME▲ to adjust the speaker volume.
- Press ►/SKIP to skip to the next message.
- Press ◀/REPEAT to repeat the message currently playing. Press ◀/REPEAT twice to listen to the previous message.
- Press X/DELETE to delete the current message. The system advances to the next message.
- Press ►/■/PLAY/STOP to stop.



# Message playback

## Listen to messages with a handset

---

1. Press **MENU** in idle mode.
2. Press **SELECT** to select **Play messages**. If you have either new or old messages, the messages play automatically. If you have both new and old messages:
  - To play new messages, press **SELECT** to select **Play new msgs**.
  - To play old messages, press **CID▼** or **▲DIR** to highlight **Play old msgs**, then press **SELECT**.

When the handset is playing a message, its screen shows the caller's name or number. If the caller's information is unavailable, the handset shows **No caller info**.

### Options during playback:

- Press **EQ**  button to adjust the message playback audio quality.
- Press **▶)/SPEAKER** to play the messages through the handset earpiece.
- Press **CID▼/VOLUME/▲DIR** to adjust the speakerphone volume.
- Press **SKIP** to skip to the next message.
- Press **REPEAT** to repeat the message currently playing. Press **REPEAT** twice to listen to the previous message.
- Press **MUTE/DELETE** to delete the current message. The handset displays **Message deleted** briefly and the system advances to the next message.
- Press **2** to pause the playback and show the caller ID information. Press **HOME/FLASH, DIAL** or **▶)/SPEAKER** to use the home line, or press **CELLULAR** to use the cell line to call back the caller. Press **OFF/CANCEL** or **BACK** to resume the playback. If you do not call back within 10 seconds, message playback resumes.
- Press **HOME/FLASH** or **CELLULAR** to pause the message playback. The handset displays **Call back?** with the caller ID information. Press **YES** to call back the caller, or **NO** to resume the message playback.
- Press **OFF/CANCEL** to stop.



[www.telephones.att.com](http://www.telephones.att.com)

The *Bluetooth*<sup>®</sup> word mark and logos are owned by Bluetooth SIG, Inc. and any use of such marks by Advanced American Telephones and its parent, VTech Holdings Limited, is under license. VTech Holdings Limited is a member of Bluetooth SIG, Inc. Other trademarks and trade names are those of their respective owners.

© 2011 Advanced American Telephones. All Rights Reserved.  
AT&T and the AT&T logo are trademarks of AT&T Intellectual Property licensed to  
Advanced American Telephones, San Antonio, TX 78219.  
Printed in China. Issue 2 AT&T 02/11.